

Vacvator



METRO 4

METRO 4-40 NDD

Compact Power. Maximum Control

Operating System		
CAN bus	Interactive colour touch screen	
Spoil Tank		
Litre Capacity	4000L	
Spoil Door	Fully opening	
Door Operation	Hydraulic	
Door Lock	Four point hydraulic wedge locking mechanism	
Tipping	Telescopic hoist with safety valve	
Water Tank		
Clean Water Tank Capacity	Integrated	2000L
Clean Water Fill Type	Backflow protected Connection at ground level	50mm (2") camlock
Vacuum System		
Power Supply	Rear engine PTO	600N.m
Blower	Shandong, ZSH150V Roots type rotary lobe, air injection	2718m³/h (1600cfm)
Filtration		
4 Stage Filtration System	Spoil tank, 2 barrel cyclone, 9 poly washable filters & blower pre-filter	
Suction Boom		
3 Function	Hydraulic 340° slew, boom up/down, boom stick in/out	5m reach
Travis Coupling	150mm (6")	
Spoil Connection Points		
Spoil Tank Inlet	Travis with knife valve	150mm (6")
Spoil Tank Dewatering Drain	Travis with knife valve	150mm (6")
Boom Inlet	Travis	150mm (6")
NDD - High Pressure Water		
Pump	Comet TW8036S	1*
Pressure	248 Bar (3600psi)	
Flow	32LPM	
Hose Size	10mm (3/8")	
Hose Length	20m	
High Pressure Lance with Turbo Nozzle	1x 1500mm & 1x 2000mm	

Remote		
Wireless Remote	12 button, 24 function, variable speed, rechargeable batteries, emergency stop	
Safety Equipment		
CAN bus Control System	Integrated safety shut down protection scales, e-stops, high water pressure, hydraulic oil temp & engine protection	
Emergency Stops	Control panel, Remote, LHS rear, RHS rear	4
Fire Extinguisher	Dry chemical ABE	4.5kg
Spoil Tank Safety Prop	Yes	
Spoil Door Safety Prop	Yes	
Safety Handrail & Maintenance Walkway	Pneumatically operated	Yes
Safety Harness Attachment Point	Yes	
Beacons	Front & Rear	Yes
Work Lights	Rear of cab, end of boom & rear of tank	Yes
LED Light Bars	Left & right hand side	Yes
UHF 80 Channel	Yes	
Storage		
Blower Frame Toolbox	Vertical three shelf	1m x 1m x .40m (400L)
Underbody Toolbox	1m (250L)*	
Hose Trays	Left & right hand side	2.4m x .50m (480L)
Lockable Hose Tray (option)	Left & right hand side	2.4m x .50m (480L)
Vacuum Hose Reel	Vacvator - Rear mounted, variable speed remote operated in/out	40m (2x 20m) 100mm (4") hose
Truck		
Volvo FE818-320Hp 4x2	Automatic transmission & airbag suspension	

* Option of two

Unit Dimensions

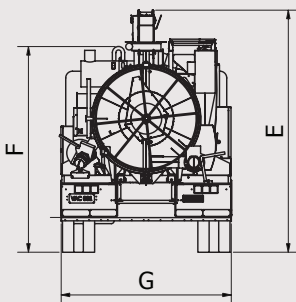
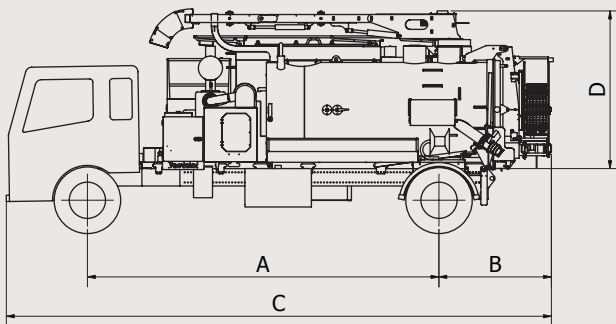

Description	Code	Dimensions (mm)
Wheelbase	A	5250
Rear Overhang	B	1775
Overall Length	C	8016
Unit Height	D	2650
Overall Height	E	3543
Overall Height - No Boom	F	3011
Overall Width	G	2500

Boom Reach

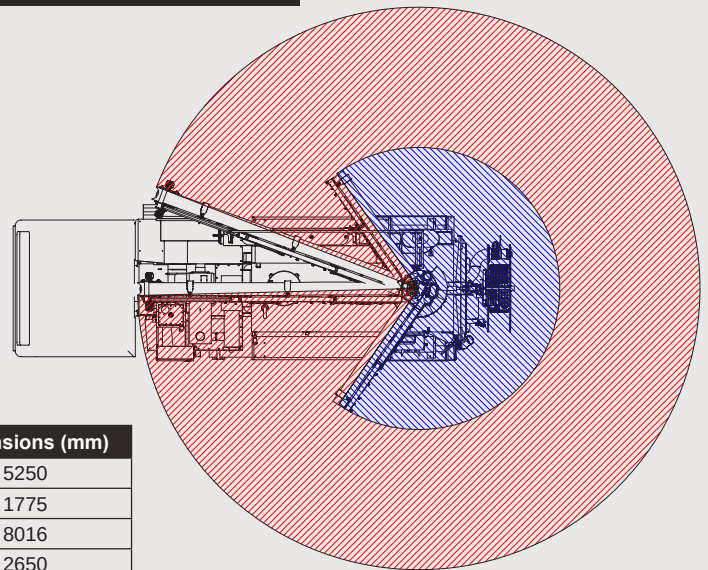

Minimum reach Maximum reach